

SENSOR FEATURES:

- Detection range of <25 to 300 ppm ammonia (NH₃).
- High selectivity to ammonia.
- Minimal response to changing environmental humidity.
- Response is unaffected by prolonged exposures to, or high concentrations of ammonia.
- Sensor response is not affected by H₂S.



Sensor Response Characteristics

The figures below show typical response and selectivity data for sensors operated in clean, dry gas.

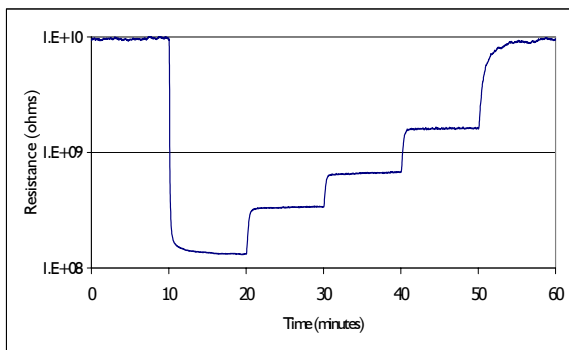

Typical sensor response to varying levels of ammonia. Air – 300 ppm – 150 ppm – 75 ppm – 25 ppm - Air

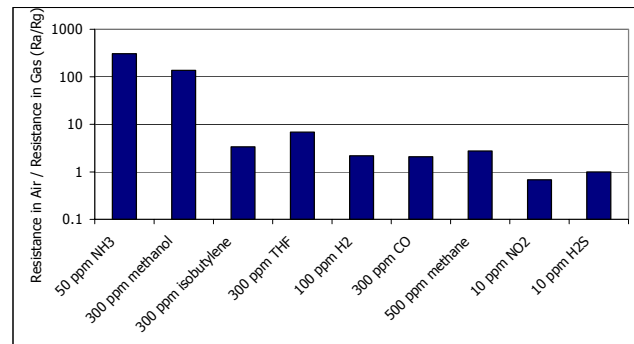

Selectivity of ammonia sensor. Note Ra/Rg = 1 indicates no response to gas, Ra/Rg < 1 indicates sensor response in opposite direction.

Electrical Characteristics

The electrical properties below are typical for Ammonia Sensors. If the actual values differ the customer will be notified with the shipment. Circuits are available that will be preset to the correct values.

Property	Symbol	Value	Remarks
Heater Power Consumption	P _H	~ 975 mW	At V _H = 7.5
Heater Voltage	V _H	7.5 VDC	
Heater Resistance	R _H	31 Ω ± 2 Ω	At room temperature
Sensing Voltage	V _C	5.0 VDC	Recommended

Circuitry

A transducer is available from Synkera to operate the sensor. This circuit, packaged on a 2" x 1.5" printed circuit board, is powered with 9 – 24 VDC. The transducer provides a 0 – 5 VDC output which can be adjusted for sensor offset and gain. The heater voltage is also adjustable. The circuit is set to the recommended values at the factory.

Basic Measuring Circuit

The sensor can be operated using a simple voltage divider. This requires two voltage supplies: heater voltage (V_H) and circuit voltage (V_C). V_H is applied to the heater in order to maintain a constant, elevated temperature, for optimum sensing. V_C is applied to allow a measurement of the output voltage (V_{out}) across a load resistor (R_L).

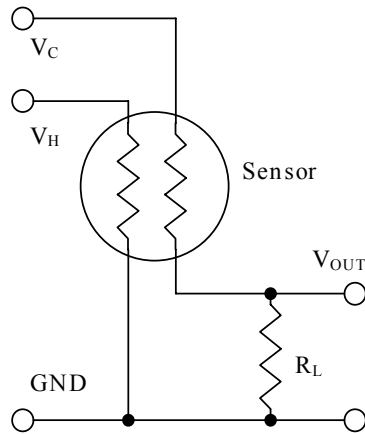

Pins 1 and 3 on the TO-39 header are attached to the heater. Apply V_H across these pins.

Pins 2 and 4 on the TO-39 header are attached to the resistive sensor element. Connect these pins in the measuring circuit.

Sensor Resistance Calculation

Sensor Resistance (R_s) is calculated using the following formula:

$$R_s = \frac{V_C - V_{out}}{V_{out}} * R_L$$

Sensor Pin Out

Top view of sensor

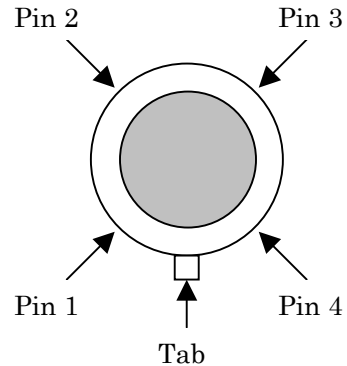

Synkera Technologies strives to be customer oriented. If you have a special application you would like to discuss, or questions you would like answered please contact us at info@synkera.com.