

# piD-TECH *plus*™

## Photoionization Sensor

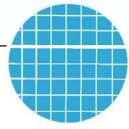

Baseline - MOCON, Inc.



### Trust our 20 years of experience with PID detectors

The piD-TECH *plus*™ Plug-in Photoionization Sensor is designed to provide complete photoionization detection capability and be installed in portable and stationary gas monitors that accept the City Technology™ - 4P cell dimensional profile. This gives many gas monitors new and powerful detection capability that was previously unavailable.

The intrinsically safe piD-TECH *plus*™ can save many years and hundreds of thousands of dollars in development of a first generation Photoionization detector (PID) for a fraction of the cost. The sample gas is exposed to an ultraviolet light from a lamp which ionizes the sample to be detected by the instrument and reported as a concentration. Chemicals such as VOCs with an ionization potential less than the eV of the lamp will be detected by photoionization. Contact Baseline for a comprehensive ionization potential list.

### Applications

- Industrial hygiene & safety monitoring
- Confined space entry
- Soil contamination and remediation
- Hazmat sites and spills
- Arson investigation
- Low concentration leak detection
- EPA method 21 and emissions monitoring

### Certifications

**USA:** UL 913 (Sixth Edition), For use in Class I, Division 1, Groups A, B, C, D Locations.

**Europe:** ATEX directives EN50014:1997 E and EN50020:2002 E, II G Eex ia IIC, Tamb -20C to +60C

**Other:** IECEx Standards IEC60079-0:2004 and IEC60079-11:1999, Ex ia IIC Tamb = -20C to +60C

**Patents:** US Pat 6,646,444, Japan Pat 3,793,757  
piD-TECH *plus*™ is a UL certified component

Detailed documentation for specific certification is available upon request. Above certifications are issued for piD-TECH *plus*™ sensor only and are not applicable to the equipment in which it is incorporated.

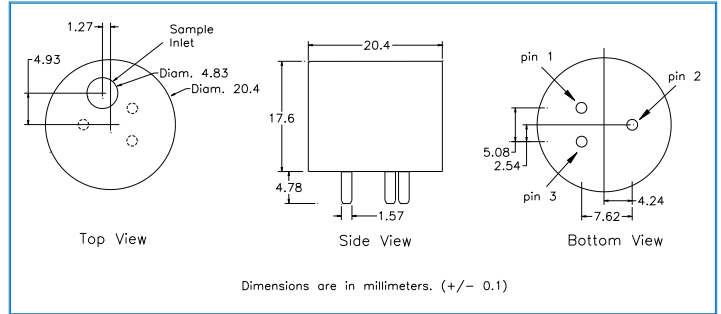

ISO 9001 CERTIFIED

INTRINSICALLY SAFE

### Performance Characteristics

	Black	Bronze	Silver
<b>Part Number</b>	042-208	042-616	042-209
<b>Range (Isobutylene):</b>	2000ppm	200ppm	20ppm
<b>Minimum Detectable Quantity (Isobutylene):</b>	50ppb	25ppb	5ppb

**Lamp Energy:** 10.6 eV

**T90 Response Time:** <20 seconds (diffusion mode)

**Temperature Range:** -20° C to 60 ° C

**Relative Humidity Range:** 0 to 90% non-condensing

**Humidity Response:** <0.2ppm @ 90% r.h. (typical)

**Humidity Quenching Effect:** <15% @ 90% r.h.

**Onboard Filter:** To remove liquids/particles

### Electrical Characteristics

**Supply Voltage:** 3.2V - 10V (input voltage regulator included)

**Current:** 20mA - 30mA

**Power Consumption:** 64mW - 300mW, dependent on supply voltage

**Output Signal:** 0.05V - 2.5V

**Entity Parameters:**

Vmax	Imax	Pi	Ci	Li
10v	Limited by internal fuse	.581W limited by fuse, zener diode & resistor	0 uF	0 H

### Physical Characteristics

**Weight:** <8g

**Package Type:** City Technology™ 4p

**Position Sensitivity:** None

**Servicable Parts:** Lamp, detector cell, filters

**Warranty Period:** 18 months from date of shipment or 12 months from date of installation, which ever comes first

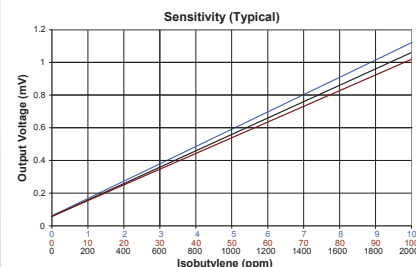

P.O. Box 649, 19661 Highway 36 • Lyons, CO 80540, U.S.A.

D017.2 05/08

P: 1.800.321.4665 • 1.303.823.6661 F: 303.823.5151 E: Sales@BaselineIndustries.com W: www.baseline-mocon.com